

IIAR

H Y D E R A B A D

International Conference On

Comprehensive Facts on Synthesis, Applications and Properties of Carbon Nan tube

Presented by: Mr. Anand Mohan

JRF(DST) P.G. DEPARTMENT OF PHYSICS

C.M.Sc. College, Darbhanga, Bihar

ABSTRACT

Carbon Nanotubes (CNTs) are allotropes of carbon with a nanostructure that can have a length-to-distance across proportion more noteworthy than 1,000,000. These round and hollow carbon atoms have novel properties that make them conceivably helpful in numerous applications in nanotechnology. Formally got from the grapheme sheet they show irregular mechanical properties, for example, high sturdiness and high flexible moduli. Alluding to their electronic structure, they display semiconducting and additionally metallic behavior and in this way cover the full scope of properties imperative for innovation. Nanotubes are ordered as single-walled nanotubes and different walled nanotubes. Strategies have been created to deliver Nanotubes in sizeable amounts, including circular segment release, laser removal, substance vapor statement, silane arrangement method and fire synthesis method. The properties and qualities of CNTs are still being inquired about intensely and researchers have scarcely started to tap the capability of these structures. Without uncertainty, carbon nanotubes speak to a material that offers incredible potential, carrying with it the likelihood of leaps forward in another era of gadgets, electric gear and bio fields. Generally speaking, late studies in regards to CNTs have demonstrated an extremely encouraging look at what lies ahead in the eventual fate of CNTs in nanotechnology, optics, hardware, and different fields of materials science.

Key words —Carbon Nano Tubes, Naohorns, Naobuds, electrical properties of CNT, Mechanical properties of CNT, Applications of CNT

INTRODUCTION

Nanotube: In 1985, a conjunction of occasions prompted to a sudden and impromptu explore different avenues regarding another sort of microscope bringing about the revelation of another particle made absolutely of carbon – the very component scientific experts felt there was nothing more to find out about. Bucky balls – sixty carbon molecules orchestrated in a soccer ball shape – had been found and the substance world, also the physical also, material universes, could never be the same. A Carbon Nanotube is a tube-molded material, made of carbon, having a distance across measuring on the nanometer scale. The graphite layer shows up to some degree like a moved up chicken wire with a consistent unbroken hexagonal work and carbon atoms at the pinnacles of the hexagons known as graphene. Carbon Nanotubes have numerous structures, varying long, thickness, and in the kind of helicity furthermore, number of layers. In spite of the fact that they are shaped from basically a similar graphite sheet, their electrical attributes vary contingent upon these varieties, acting either as metals or as semiconductors. Essential carbon in the

sp² hybridization can frame a assortment of astounding structures .Apart from the outstanding graphite; carbon can construct shut and open enclosures with honeycomb nuclear plan. The main such structure to be found was the C₆₀ atom by Kroto et al 1985 .Albeit different carbon enclosures were concentrated on, it was just in 1991, when Iijima watched interestingly tubular carbon structures .The Nanotubes comprised of up to a few many graphitic shells (alleged multi-walled carbon nanotubes (MWNT)) with adjoining shell partition of 0.34 nm, breadths of 1 nm and high length/measurement proportion. As a gathering, Carbon Nanotubes ordinarily have distances across running from <1 nm up to 50 nm. Their lengths are regularly a few microns, however late headways have made the Nanotubes any longer, and measured in centimeters. A graphene sheet can be moved more than one way, delivering diverse sorts of carbon Nanotubes .and consequently Carbon Nanotubes can be arranged by their structures:

SINGLE-WALLB NANOTUBES (SWNT) INTRODUCTION

Nanotube: In 1985, a conjunction of occasions prompted to a sudden and impromptu explore different avenues regarding another sort of microscope bringing about the revelation of another particle made absolutely of carbon – the very component scientific experts felt there was nothing more to find out about. Bucky balls – sixty carbon molecules orchestrated in a soccer ball shape – had been found and the substance world, also the physical also, material universes, could never be the same. A Carbon Nanotube is a tube-molded material, made of carbon, having a distance across measuring on the nanometer scale. The graphite layer shows up to some degree like a moved up chicken wire with a consistent unbroken hexagonal work and carbon atoms at the pinnacles of the hexagons known as graphene. Carbon Nanotubes have numerous structures, varying long, thickness, and in the kind of helicity furthermore, number of layers. In spite of the fact that they are shaped from basically a similar graphite sheet, their electrical attributes vary contingent upon these varieties, acting either as metals or as semiconductors. Essential carbon in the sp² hybridization can frame a assortment of astounding structures .Apart from the outstanding graphite; carbon can construct shut and open enclosures with honeycomb nuclear plan. The main such structure to be found was the C₆₀ atom by Kroto et al 1985

.Albeit different carbon enclosures were concentrated on, it was just in 1991, when Iijima watched interestingly tubular carbon structures .The Nanotubes comprised of up to a few many graphitic shells (alleged multi-walled carbon nanotubes (MWNT)) with adjoining shell partition of 0.34 nm, breadths of 1 nm and high length/measurement proportion. As a gathering, Carbon Nanotubes ordinarily have distances across running from <1 nm up to 50 nm. Their lengths are regularly a few microns, however late headways have made the Nanotubes any longer, and measured in centimeters. A graphene sheet can be moved more than one way, delivering diverse sorts of carbon Nanotubes .and consequently Carbon Nanotubes can be arranged by their structures:

SINGLE-WALL NANOTUBES (SWNT)

Most Single-Walled Nanotubes (SWNT) have a distance across of near 1 nanometer, with a tube length that can be a huge number of times longer. The structure of a SWNT can be conceptualized by wrapping a one-molecule thick layer of graphite called graphene into a consistent chamber. The way the graphene sheet is wrapped is spoken to by a couple of records (n,m) called the chiral vector. The whole number's n and m mean the quantity of unit vectors along two bearings in the honeycomb precious stone cross section of graphene. In the event that m

$n = 0$, the Nanotubes are called "zigzag", which is named for the example of hexagons as we proceed onward outline of the tube. In the event that $n = m$, the Nanotubes are called "rocker", which depicts one of the two conformers of cyclohexene a hexagon of

carbon molecules. Something else, they are called "chiral", in which the m esteem lies amongst crisscross and rocker structures. The word chiral implies handedness and it shows that the tubes may turn in either bearing.

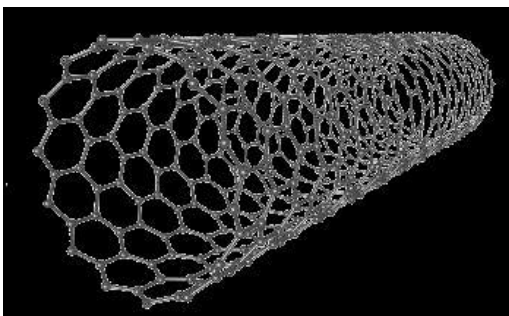

Figure 1: Single walled Carbon Nanotube

1.2. MWNTS- MULTIPLE WALLED CARBON NANOTUBES

There are two models which can be utilized to depict the structures of multi-walled nanotubes. In the Russian Doll display, sheets of graphite are masterminded in concentric barrels, e.g. A single-walled nanotube (SWNT) inside a larger single-walled nanotube. In the Material model, a solitary sheet of graphite is come in around itself, looking like a look of material or a moved daily paper. The interlayer remove in multi-walled nanotubes is near the separation between graphene layers in graphite, roughly 3.3 \AA (330 pm). The extraordinary place of Double-walled carbon nanotubes (DWNT) must be Accentuated here in light of the fact

that their morphology and properties are like SWNT yet their imperviousness to chemicals is essentially made strides. This is particularly essential when Functionalization is required (this implies joining of substance capacities at the surface of the nanotubes) to add new properties to the CNT. On account of SWNT, covalent Functionalization will break some $C=C$ double bonds, leaving "openings" in the structure on the nanotube and therefore adjusting both its mechanical and electrical properties. On account of DWNT, just the external divider is adjusted. DWNT synthesis on the gram-scale was initially proposed in 2003 by the CCVD strategy, from the particular diminishment of oxide arrangements in methane and hydrogen.

Figure-2: a) Double-wall Nanotubes (DWNT) b) Multiwalled Nanotubes

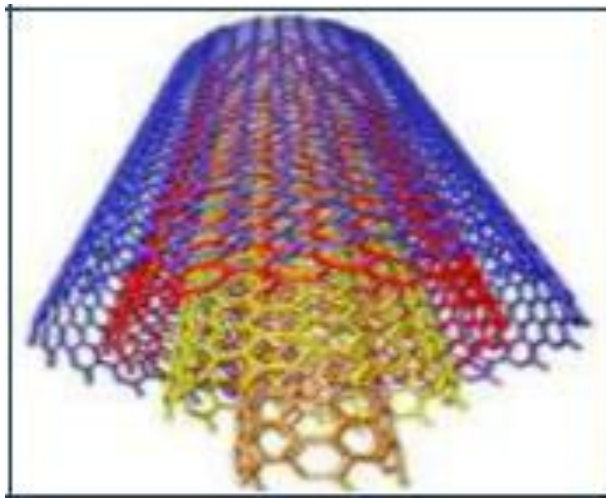
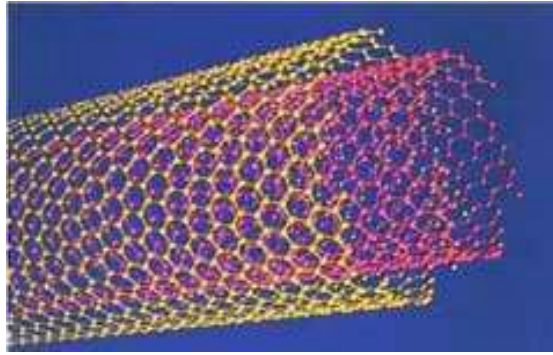

Table 1- Comparison between SWNT and MWNT [6]

S.No.	SWNT	MWNT
1	Single layer of graphene	Multiple layer of graphene
2	Catalyst is required for synthesis	Can be produced without catalyst
3	Bulk synthesis is difficult as it requires Bulk synthesis is difficult as it requires atmospheric condition	Bulk synthesis is easy
4	Purity is poor	Purity is high
5	A chance of defect is more during Functionalization	A chance of defect is le improve
6	Less accumulation in body	More accumulation in body
7	It can be easily twisted and are more pliable	It cannot be easily twisted

1.3 NANOTORUS

A nanotorus is hypothetically portrayed as carbon nano tube bent into a torus (doughnut shape).. Nanotori are anticipated to have numerous exceptional properties, for example, attractive minutes

1000 times bigger than already expected for certain particular radii. Properties, for example, attractive minute, warm security and so on fluctuates generally relying upon sweep of the torus and span of the tube. Nano-torus particles are promising in nano-photonics applications

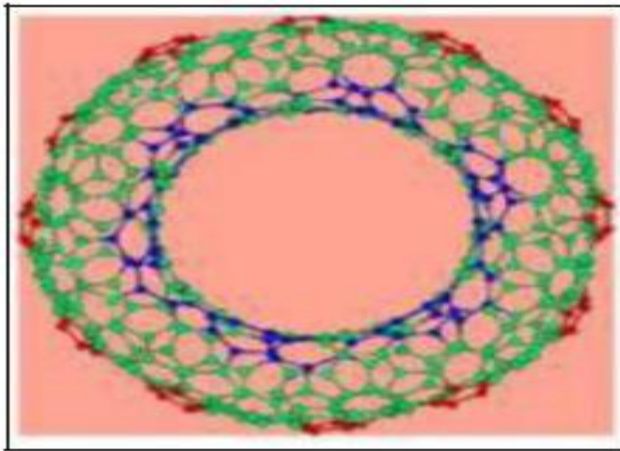

Figure-3 A nanotorus is hypothetically

1.4. NANO-BUDS

Carbon Nanobuds are a newly created material combining two previously discovered allotropes of carbon; carbon nanotubes and fullerenes. In this new material fullerene-like "buds" are covalently bonded to the outer sidewalls of the underlying carbon nanotube. This hybrid material has useful properties of both fullerenes and carbon nanotubes. In particular, they have been found to be exceptionally good field emitters. In

composite materials, the attached fullerene molecules may function as molecular anchors preventing slipping of the nanotubes, thus improving the composite's mechanical properties.

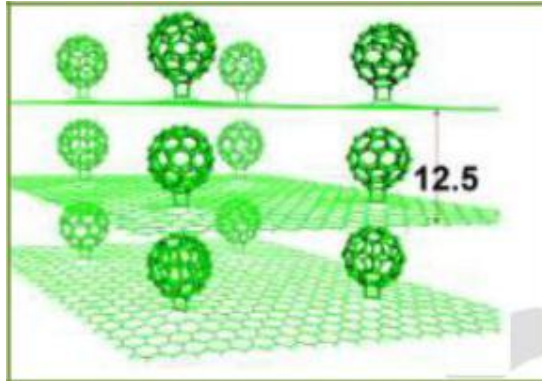

Figure-4 Carbon Nan buds

1.5NANO NORNS

They were first reported by Harris et al and Iijima et.al. Single-walled carbon nanohorns (SWCNHs) are horn-shaped single walled tubules with a conical tip. The primary advantage of SWNHs is that no catalyst is required for synthesis so high purity materials can be produced. Their high surface area and excellent electronic properties have led to

promising results for their use as electrode material for energy storage. Currently, SWCNHs have been widely studied for various applications, such as gas storage, adsorption, catalyst support, drug delivery system, magnetic resonance analysis, electrochemistry, biosensing application, photovoltaics, photoelectrochemical cells, photodynamic therapy, fuel cells, and so on.

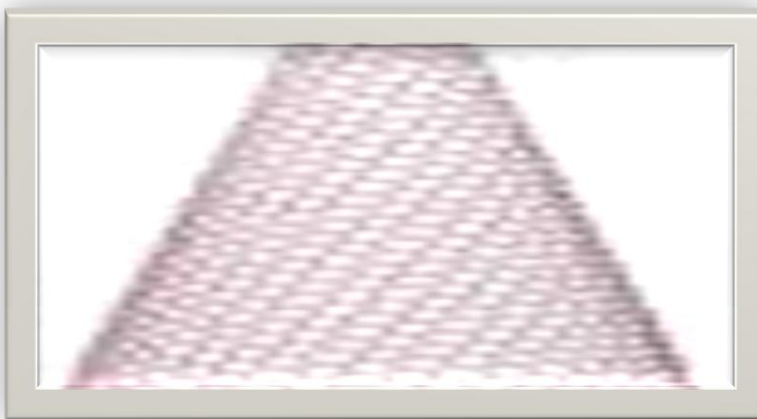

Figure 5: Carbon Nan horns

The carbon atoms in nanotubes are incredible different sorts of particles for a few reasons: at framing covalent bonds with numerous Carbon atoms have a characteristic ability to

frame covalent bonds with numerous different components as a result of a property called electronegativity. Electronegativity is a measure of how emphatically a particle clutches electrons circling about it. The electronegativity of carbon (2.5) is about amidst the scope of electronegativity of different substances from potassium (0.8) to fluorine. Since carbon has electronegativity amidst the range, it can frame stable covalent bonds with a substantial number of components.

- All the carbon atoms in nanotubes are on the surface of the nanotube and thusly open to different molecules.
- The carbon atoms in nanotubes are cling to just three different molecules, so they have the ability to attach to a fourth particle.
- These elements make it moderately simple to covalently security assortment of particles or atoms to nanotubes, which changes the substanceproperties of the nanotube. (This technique is called Functionalization). Taking this holding thing further, if the particles connected tothe carbon nanotubes also attach to carbon fibers, the functionalized carbon nanotubes can bond to the fibers in a compositeproducing a stronger material.

1.METHODS OF PRODUCTIONS OF CNTS:

2.1. PLASMA BASED SYNTHESIS METHODS:

a. Arc Discharge Method

The circular segment evaporation strategy, which creates the best quality nanotubes, includes passing a current of around 50 amps between two graphite electrodes in an air of helium. This causes the graphite to vaporize, some of it consolidating on the dividers of the response vessel and some of it on the cathode. It is the store on the cathode which contains the carbon nanotubes. Single-walled nanotubes are delivered when Co and Ni or some other metal is added to the anode. It has been known since the 1950s, if not prior, that carbon nanotubes can likewise be made by passing a carbon-containing gas, for example, a hydrocarbon, over an impetus. The impetus comprises of nano-sized particles of metal, generally Fe, Co or Ni. These particles catalyze the breakdown of the vaporous molecules into carbon, and a tube then starts to develop with a metal molecule at the tip]. In 1991, Iijima reported the planning of another sort of limited carbon structures comprising of needle-like tubes .The tubes were delivered utilizing a bend release evaporation technique like that utilized for the fullerene synthesis.

The carbon needles, extending from 4 to 30 nm in breadth and up to 1 mm long, were developed on the negative end of the carbon anode utilized for the direct current (dc) bend

release evaporation of carbon in an argon-filled vessel (100 Torr). The flawlessness of carbon nanotubes delivered along these lines has by and large been poorer than those made by circular segment evaporation, yet awesome enhancements in the method have been made as of late. The enormous preferred standpoint of catalytic synthesis over circular segment evaporation is that it can be scaled up for volume generation. The third critical strategy for making carbon nanotubes includes utilizing a capable laser to vaporize a metal-graphite target. This can be utilized to create single-walled tubes with high return

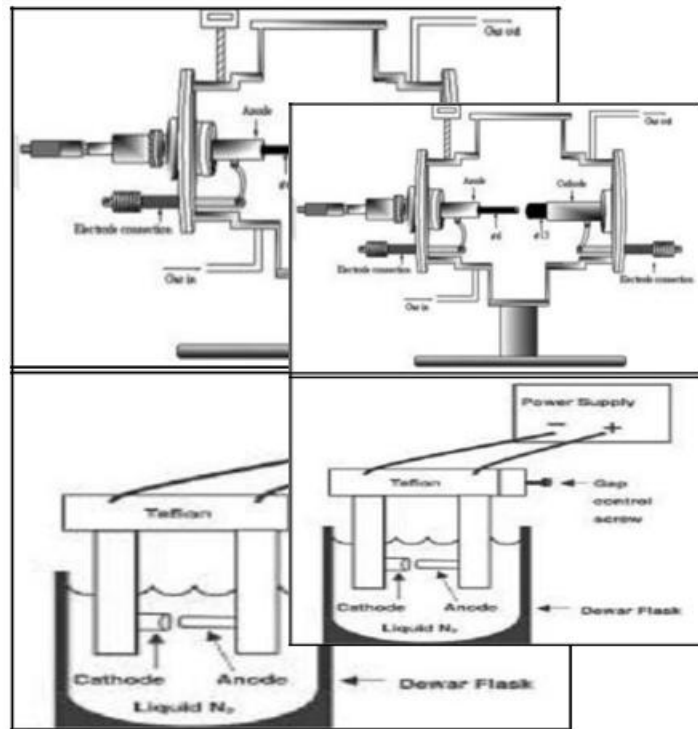

Figure6: (a) Schematic representation of arc discharge apparatus. (b) Experimental arc discharge set-up in liquid N₂.

b. Laser Ablation Method

First large-scale (gram quantities) production of SWNTs was achieved in 1996 by the Smalley's group at Rice University. A pulsed or continuous laser is used to vaporize a 1.2 at. % of cobalt/nickel with 98.8 at.% of graphite composite target that is placed in a 1200°C quartz tube furnace with

an inert atmosphere of ~500 Torr of Ar or He. Nanometer-size metal catalyst particles are formed in the plume of vaporized graphite. The metal particles catalyze the growth of SWNTs in the plasma plume, but many by-products are formed at the same time. As the vaporized species cool, small carbon molecules and atoms quickly condense to form larger clusters, possibly including

fullerenes. The catalysts also begin to condense, but more slowly at first, and attach to carbon clusters and prevent their closing into cage structures. Catalysts may even open cage structures when they attach to them. From these initial clusters, tubular molecules grow into single-wall carbon nanotubes until the catalyst particles become too large, or until conditions have cooled sufficiently that carbon no longer can diffuse through or over the surface of the catalyst particles. It is also possible that the particles become that much coated with a carbon layer that they cannot absorb more and the nanotube stops growing. The SWNTs shaped for this situation are packaged together by van der Waals strengths. The nanotubes and by-items are gathered by means of buildup on a cool finger downstream from the objective. On a basic level, circular segment release and laser removal are comparable techniques, as both utilize a metal-impregnated graphite target (anode) to

create SWNTs, and both deliver MWNT and fullerenes when immaculate graphite is utilized. Nonetheless, the length of MWNT delivered through laser removal is much shorter than that created by circular segment release technique. Along these lines, this technique does not appear to be sufficient for the synthesis of MWNT. The width dissemination of SWNTs made by this technique is generally somewhere around 1.0 and 1.6 nm. Due to the great nature of nanotubes created by this technique, researchers are attempting to scale up laser removal. Notwithstanding, the outcomes are not yet in the same class as for the curve release technique, yet they are as yet encouraging. Two new improvements in this field are ultra quick Pulses from a free electron laser technique the consistent wave laser-powder strategy.

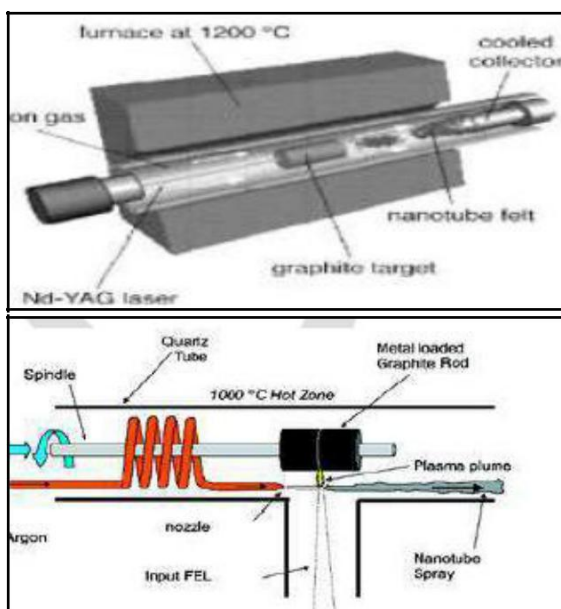

Figure 7: Schematic synthesis apparatus. (a) Classical laser ablation technique. (b) Ultrafast laser evaporation (FEL-frelectron laser)

2.2 Thermal Synthesis Process:

Arc discharge and laser ablation methods are fundamentally plasma based synthesis. However, in thermal synthesis, only thermal energy is relied and the hot zone of reaction never goes beyond 1200 °C, including the case of plasma enhanced CVD. In almost all cases, in presence of active catalytic species such as Fe, Ni, and Co, carbon feedstock produces CNTs. Depending on the carbon feedstock; Mo and Ru are sometimes added as promoters to render the feedstock more active for the formation of CNTs. In fact, thermal synthesis is a more generic term to represent various chemical vapor deposition methods. It includes Chemical Vapor Deposition processes, Carbon monoxide synthesis processes and flame synthesis.

2.2.1. Chemical vapor deposition (CVD)

While the arc discharge method is capable of producing large quantities of unpurified nanotubes, significant effort is being directed towards production processes that offer more controllable routes to the

synthesize synthesis. A class of processes that seems to offer the best chance to obtain a controllable process for the selective production of nanotubes with predefined properties is chemical vapour deposition (CVD) [19]. In principle, chemical vapour deposition is the catalytic decomposition of hydrocarbon or carbon monoxide feedstock with the aid of supported transition metal catalyst. It is carried out in two step process:-

- Catalyst is deposited on substrate and then nucleation of catalyst is carried via chemical etching or thermal annealing. Ammonia is used as an etchant. Metal catalysts used are Ni, Fe or Co
- Carbon source is then placed in gas phase in reaction chamber. Then carbon molecule is converted to atomic level by using energy source like plasma or heated coil. This carbon will get diffused towards substrate, which is coated with catalyst and Nanotubes grow over this metal catalyst. Carbon source used is methane, carbon monoxide or acetylene. Temperature used for synthesis of nanotube is 650 – 9000 °C range. The typical yield is 30%.

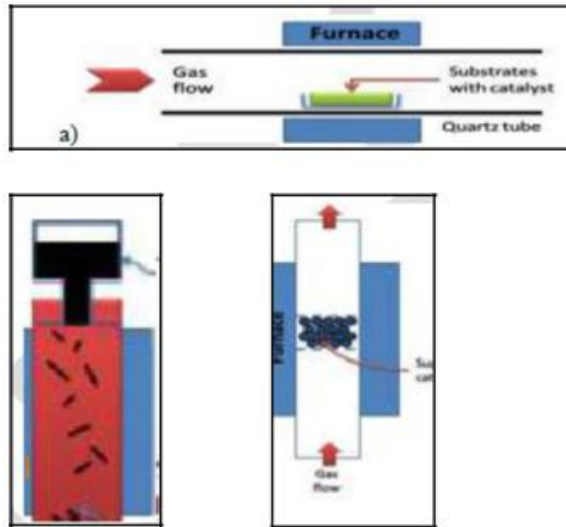

Figure 8: Schematic demonstration of CVD method. (a) Horizontal furnace. (b) Vertical furnace. (c) Fluidized bed reactor.

Using CVD method, several structural forms of carbon are formed such as amorphous carbon layers on the surface of the catalyst, filaments transition metal, and the saturation of carbon atoms in the metal nanoparticle. The precipitation of carbon from the metal particle leads to the formation of tubular carbon solids in a sp^2 structure. The characteristics of the carbon nanotubes produced by CVD method depend on the working conditions such as the temperature and the operation pressure, the kind, volume and concentration of hydrocarbon, the nature, size and the pretreatment of metallic catalyst, the nature of the support and the reaction time.

2.2.2. Plasma Enhanced CVD (PECVD):

Plasma-enhanced chemical vapor deposition (PECVD) systems have been used to produce of amorphous carbon, graphite layers covering metal both SWNTs and MWNTs. PECVD is a general term, encompassing several differing synthesis methods. In general PECVD can be direct or remote. Direct PECVD systems can be used for the production of MWNT field emitter towers and some SWNTs. A remote PECVD can also be used to produce both MWNTs and SWNTs (Figure 6). For SWNT synthesis in the direct PECVD system, the researchers heated the substrate up to 550 to 850°C , utilized a CH_4/H_2 gas mixture at 500 mT, and applied 900 W of plasma power as well as an externally applied magnetic field

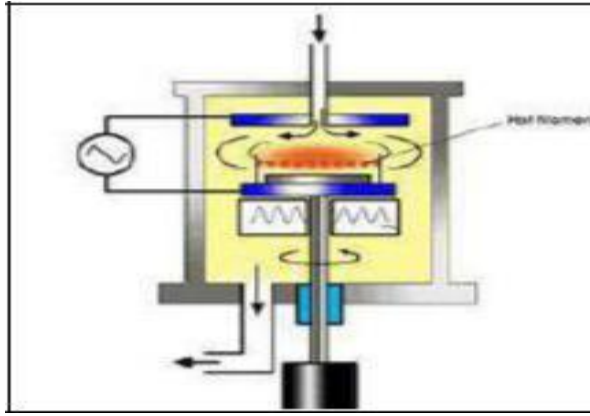

Figure 9 Plasma-enhanced chemical vapor deposition (PECVD) systems

The plasma enhanced CVD method generates a glow discharge in a chamber or a reaction furnace by a high frequency voltage applied to both electrodes. A substrate is placed on the grounded electrode. In order to form a uniform film, the reaction gas is supplied from the opposite plate. Catalytic metal, such as Fe, Ni and Co are used on a Si, SiO₂, or glass substrate using thermal CVD or sputtering. As such, PECVD and HWCVD is

2.2.3. Alcohol Catalytic CVD (ACCVD):

Low cost production of SWNT in large scale in Alcohol catalytic CVD (ACCVD). Evaporated methanol and ethanol are being utilized over iron and cobalt catalytic metal particles supported with zeolite. CNT is obtained at a relatively low minimum temperature of about 550 °C. It seems that

essentially a crossover between plasma-based growth and CVD synthesis. In contrast, to arc discharge, laser ablation, and solar furnace, the carbon for PECVD synthesis comes from feedstock gases such as CH₄ and CO, so there is no need for a solid graphite source. The argon-assisted plasma is used to break down the feedstock gases into C₂, CH, and other reactive carbon species (C_xH_y) to facilitate growth at low temperature and pressure.

hydroxyl radicals, who come from reacting alcohol on catalytic metal particles, remove carbon atoms with dangling bonds, which are obstacles in creating high-purity SWNTs. The diameter of the SWNTs produced is about one nm.

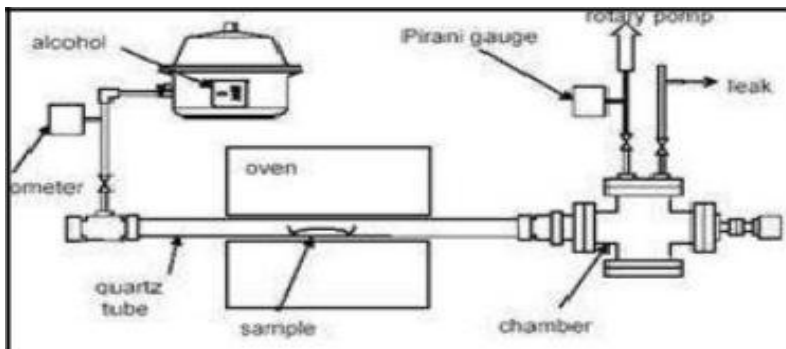

Figure 10: Alcohol catalytic CVD

2.3. The Hydrothermal Methods

Sonochemical/hydrothermal technique is another synthesis method which is successful for the preparation of different carbonaceous nanoarchitectures such as nano-onions, nanorods, nanowires, nanobelts, MWNTs. This process has many advantages in comparison with other methods: the starting materials are easy to obtain and are stable in ambient temperature;

ii) it is low temperature process (about 150–180 °C);

there is no hydrocarbon or carrier gas necessary for the operation. MWNTs were produced by hydrothermal processing where a mixture of polyethylene and water with a Ni catalyst is heated from 700 to 800 °C under 60–100 MPa pressure. Both closed and open end multiwall carbon nanotubes with the wall thickness from several to more than 100 carbon layers were produced. An important feature of hydrothermal nanotubes is the small wall thickness and large inner core diameter, 20–800 nm. Graphitic carbon nanotubes were

synthesized by the same research group using ethylene glycol (C₂H₄O₂) solution in the presence of Ni catalyst at 730–800 °C under 60–100 MPa pressure [25,26]. TEM analysis shows that these carbon nanotubes have long and wide internal channels and Ni inclusions in the tips. Typically, hydrothermal nanotubes have wall thickness 7–25 nm and outer diameter of 50–150 nm. Thin-wall carbon tubes with internal diameters from 10–1000 nm have been also produced. During growth of a tube, the synthesis fluid, which is a supercritical mixture of CO, CO₂, H₂O, H₂, and CH₄ enters the tube. Manafi et al. have prepared large quantity of carbon nanotubes using sonochemical/hydrothermal method. 5 mol/l NaOH aqueous solution of dichloromethane, CCl₂ and metallic Li was used as starting materials. The hydrothermal synthesis was conducted at 150–160 °C for 24 h. The nanotubes produced in this way were about 60 nm in diameter and 2–5 μm long. Uniformly distributed catalyst nanoparticles were observed by SEM analysis as a result of the ultrasonic pre-treatment of the starting

solution. Multiwall carbon nanocells and multiwall carbon nanotubes have been artificially grown in hydrothermal fluids from amorphous carbon, at temperatures below 800 °C, in the absence of metal catalysts [26]. Carbon nanocells were formed by interconnecting multiwalls of graphitic carbon at 600 °C. The bulk made of connected hollow spherical cells appears macroscopically as disordered carbon. The nanocells have diameters smaller than 100 nm, with outer diameters ranging from 15 to 100 nm, and internal cavities with diameters from 10 to 80 nm. The nanotubes observed in the sample have diameters in the range of tens and length in the range of hundreds of nanometers.

3. PURIFICATION OF CNTs

Nanotubes usually contain a large amount of impurities such as metal articles, amorphous carbon, and multishell. There are different steps in purification of nanotubes .

3.1 Air Oxidation:

The carbon nanotubes are having less purity; the average purity is about 5- 10%. So purification is needed before attachment of drugs onto CNTs. purification of single-walled carbon nanotubes (SWCNTs), based on the selective oxidation of carbonaceous impurities by heating at a constantly increasing temperature (i.e. dynamic oxidation) in air. Air oxidation is useful in reducing the amount of amorphous carbon and

metal catalyst particles (Ni, Y). Optimal oxidation condition is found to be at 673 k for 40 min. dynamic oxidation allows for an efficient removal of carbonaceous impurities without significant loss of nanotubes

3.2 Acid Refluxing

Refluxing the sample in strong acid is effective in reducing the amount of metal particles and amorphous carbon. Different acids used were hydrochloric acid (HCl), nitric acid (HNO₃) and sulphuric acid (H₂SO₄), but HCl was identified to be the ideal refluxing acid.

3.3 Surfactant aided sonication, filtration and annealing

After acid refluxing, the CNTs were purer but, tubes were entangled together, trapping most of the impurities, such as carbon particles and catalyst particles, which were

Difficult to remove with filtration. So surfactant-aided sonication was carried out. Sodium dodecyl benzene sulphonate (SDBS) aided sonication with ethanol (or methanol) as organic solvent were preferred because it took the longest time for CNTs to settle down, indicating an even suspension state was achieved. The sample was then filtered with an ultra filtration unit and annealed at 1273 k in N₂ for 4 h. Annealing is effective in optimizing the CNT structures. It was proved the surfactant-aided sonication is effective to

untangle CNTs, thus to free the particulate impurities embedded in the entanglement. Nanotube can also be purified by multi-step purification method.

4. PROPERTIES OF CNTs

4.1 Mechanical Properties

Carbon nanotubes are the strongest and stiffest materials yet discovered in terms of tensile strength and elastic modulus respectively. This strength results from the covalent sp^2 bonds formed between the individual carbon atoms. Because of C-C bonds, CNTs are expected to be extremely strong along their axes and have a very large value of a SWNT is

estimated as high as 1Tpa to 1.8 Tpa. The high value of elastic modulus makes it suitable for the application as probe tips of scanning microscopy. The modulus of a SWNT depends on the diameter and chirality. However, in the case of MWNT, it correlates to the amount disorder in the sidewalls. For MWNTs, experiments have indicated that only the outer graphitic shell can support stress when the tubes are dispersed in an epoxy matrix^{1,3}, and for single wall nanotube bundles (also known as ropes), it has been demonstrated that shearing effects due to the weak inter tube cohesion gives significantly reduced moduli compared to individual

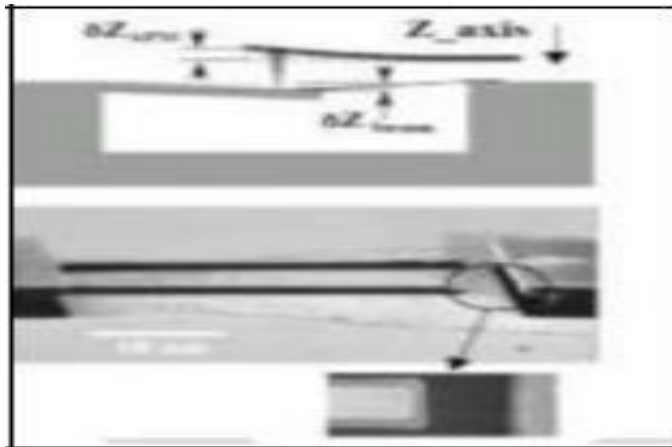

Figure 11: Tensile Strength and Elastic modulus of CNT

A single perfect nanotube is about 10 to 100 times stronger than steel per unit weight. The Young's modulus of the best nanotubes can be as high as 1000 GPa which is approximately 5x higher than steel. The tensile strength, or breaking strain of nanotubes can be up to 63 GPa, around 50x higher than steel. These properties, coupled

with the lightness of carbon nanotubes, give them great potential in applications such as aerospace. It has even been suggested that nanotubes-to-spacecoul cable first proposed by Arthur C. Clarke. The electronic properties of carbon nanotubes are also extraordinary. Especially notable is the fact that nanotubes can be metallic or

semiconducting depending on their structure. Thus, some nanotubes have conductivities higher than that of copper, while others behave more like silicon. There is great interest in the possibility of constructing nanoscale electronic devices from nanotubes, and some progress is being made in this area. However, in order to construct a useful device we would need to arrange many thousands of nanotubes in a defined pattern, and we do not yet have the degree of control necessary to achieve this. There are several areas of technology where carbon nanotubes are already being used. These include flat-panel displays, scanning probe microscopes and sensing devices. The unique properties of carbon nanotubes will undoubtedly lead to many more applications.

Table-2: Comparison of Mechanical Properties of CNTs with other string materials .

Material	Young's (GPa)mod	Tensile Strength (GPa)	Density (g/cm ³)
Single wall nanotube	1054	150	N/A
Multi wall nanotube	1200	150	2.6
Steel	208	0.4	7.8
Epoxy	3.5	0.005	1.25
Wood	16	0.008	0.6

4.2 Electrical Properties

Not only are carbon nanotubes extremely strong, but they having very interesting electrical properties. A single graphite sheet is a semimetal, which means that it ha propertiesintermediatebetweensemiconducto rs (like the silicon in computer chips, where electrons have restricted motion) and metals (like the copper used in wires, where electrons can move freely). When a graphite sheet is rolled into a nanotube, not only do the carbon atoms have to line up around the circumference of the tube, but the quantum mechanical wave functions of the electrons

must also match up. Remember, in quantum mechanics the electrons. In theory, metallic

nanotubes can carry an electrical current density of 4×10^9 A/cm² which is more than 1,000 times greater than metals such as copper . Individual nanotubes, like macroscopic structures, can be characterized by a set of electrical properties resistance, capacitance and inductance which arise from the intrinsic structure of the nanotube and its interaction with other objects. Electrical transport inside the CNTs is affected by

scattering by defects and by lattice vibrations that lead to resistance, similar to that in bulk materials. However, the 1D nature of the CNT and their strong covalent bonding

drastically affects these processes. Scattering by small angles is not allowed in a 1D material, only forward and backward motion of the carriers. Most importantly the 1D nature of the CNT leads to a new type of quantized resistance related to its contacts with three-dimensional (3D) macroscopic objects such as the metal electrodes. For a metallic CNT, $M=2$ so that

$R_Q = h/4e^2 = 6.45 \text{ k}\Omega$. Of course, as well as this quantum resistance there are other forms of contact resistance such as that attributable to the presence of Schottky barriers at metal–semiconducting nanotube interfaces and parasitic resistance, which is simply due to bad contacts. At the other extreme, in long CNTs, or at high bias, many scattering collisions can take place and the so-called Diffusive limit of transport that is typical of conventional conductors is reached. In this limit the carriers have a finite mobility. However, in CNTs this can be very high as much as 1,000 times higher than in bulk silicon. The intrinsic electronic structure of a CNT also leads to a capacitance that is es like a transmission line owing to its inductance. (41, 42)

4.3 Thermal Properties:

All nanotubes are expected to be very good thermal conductors along the tube, exhibiting

a property known as "ballistic conduction,"but good insulators laterally to the tube axis. It is predicted that carbon related to its density-of-states that is, how its energy states are distributed in energy and it is independent of electrostatics. This quantum capacitance, C_Q , is small of the order of $10^{-16} \text{ F } \mu\text{m}^{-1}$. In addition to C_Q , a CNT incorporated in a structure has an electrostatic capacitance, C_G , which arises from its coupling to surrounding conductors and as such depends on the device geometry and dielectric structure. Finally, CNTs have inductance, which is a resistance to any changes in the current flowing through them. Again, there is a quantum and a classical contribution. Classical self inductance depends on the CNT diameter, geometry of the structure and the magnetic permeability of the medium. The total inductance is the sum of the two values, so that the larger inductance, L_K , dominates ($L_K \approx 16 \text{ nH } \mu\text{m}^{-1}$, $L_C \approx 1 \text{ nH } \mu\text{m}^{-1}$). In response to an a.c. signal, a CNT behave nanotubes will be able to transmit up to $6000 \text{ W}\cdot\text{m}^{-1}\cdot\text{K}^{-1}$ at room temperature; compare this to copper, a metal well-known for its good thermal conductivity, which transmits $385 \text{ W}\cdot\text{m}^{-1}\cdot\text{K}^{-1}$. The temperature stability of carbon nanotubes is estimated to be up to

2800 °C in vacuum and about 750 °C in air. Thermal expansion of CNTs will be largely isotropic, which is different than Conventional graphite fibers, which are strongly anisotropic. This may be beneficial for carbon-carbon composites. It is expected that low-defect CNTs will have very low coefficients of thermal expansion.

4.4 Chemical Properties:

The chemical reactivity of a CNT is, compared with a graphene sheet, enhanced as a direct result of the curvature of the CNT surface. This curvature causes the mixing of the π and σ orbital, which leads to hybridization between the orbitals. The degree of hybridization becomes larger as the diameter of a SWNT gets smaller.

Hence, carbon nanotube reactivity is directly related to the π -orbital mismatch caused by an increased curvature. Therefore, a distinction must be made between the sidewall and the end caps of a nanotube. For the same reason, a smaller nanotube diameter results in increased reactivity. Covalent chemical modification of either sidewalls or end caps has shown to be possible. For example, the solubility of CNTs in different solvents can be controlled this way. However, covalent attachment of molecular species to fully sp^2 -bonded carbon atoms on the nanotube sidewalls proves to be

difficult. Therefore, nanotubes can be considered as usually chemically inert.

4.5 Optical Properties:

Optical properties of SWNT are related to their quasi one-dimensional nature. Theoretical studies have revealed that the optical activity of chiral nanotubes disappears if the nanotubes become larger therefore, it is expected that other physical properties are influenced by these parameters too. Use of the optical activity might result in optical devices in which CNTs play an important role.

5. APPLICATIONS OF CNTS

Various applications of CNTs are as follows:

- **Carrier for Drug delivery:** Carbon nanohorns (CNHs) are the spherical aggregates of CNTs with irregular horn like shape. Research studies have proved CNTs and CNHs as a potential carrier for drug delivery system.

Functionalized carbon nanotubes are reported for targeting of Amphotericin B to Cells 3) Cisplatin incorporated oxidized SWNHs have showed slow release of Cisplatin in aqueous environment. The released Cisplatin had been effective in terminating the growth of human lung cancer cells, while the SWNHs alone did not show anticancer activity.

- Anticancer drug Polyphosphazene platinum given with nanotubes had enhanced permeability, distribution and retention in the brain due to controlled lipophilicity of Nanotubes

- Antibiotic, Doxorubicin given with nanotubes is reported for enhanced intracellular penetration. The gelatin CNT mixture (hydrogel) has been used as potential carrier system for biomedical

- CNT-based carrier system can offer a successful oral alternative administration of Erythropoietin (EPO), which has not been possible so far because of the denaturation of EPO by the gastric environment conditions and enzymes.

- They can be used as lubricants or glidants in tablet manufacturing due to nanosize and sliding nature of graphite layers bound with Van der Waals forces

In Genetic Engineering: In genetic engineering, CNTs and CNHs are used to manipulate genes and atoms in the development of bioimaging genomes, proteomics and tissue engineering. The unwound DNA (single stranded) winds around SWNT by connecting its specific nucleotides and causes change in its electrostatic property. This creates its potential application in diagnostics

(polymerase chain reaction) and in therapeutics. Wrapping of carbon nanotubes by single-stranded DNA was found to be sequence-dependent, and hence can be used in DNA analysis. Nanotubes due to their unique cylindrical structure and properties are used as carrier for genes (gene therapy) to treat cancer and genetic disorders. Their tubular nature has proved them as a vector in gene therapy. Nanotubes complexed with DNA were found to release DNA before it was destroyed by cells defense system, boosting transfection significantly. Nanostructures have shown antiviral effect in respiratory syncytial virus (RSV), a virus with severe bronchitis and asthma³⁴. The treatment is generally done by combining nanoparticles and gene slicing technologies. Here RNA fragments capable of inhibiting a protein (which is needed for virus multiplication) is encapsulated within nanotubes and administered in the form of nasal sprays or drops. The promising results have been noted inhibiting further growth of virus. Nanotubes are reported for helical crystallisation of proteins and growth of embryonic rat brain neurons. Streptavidin protein is successfully immobilized on CNT via 1-pyrene butanoic acid and succinimidylester³². Nanotubes and nanohorns can adhere various antigens on their surface, hence act as source of antigen in vaccines. Hence, by use of nanotubes, use

of dead bacteria as source for antigen which is sometimes dangerous can be avoided.

Biomedical applications

Bianco et al. have prepared soluble CNTs and have covalently linked biologically active peptides with them. This was demonstrated for viral protein VP1 of foot mouth disease virus (FMDV) showing immunogenicity and eliciting antibody response. In chemotherapy, drug embedded nanotubes attack directly on viral ulcers and kills viruses.

No antibodies were produced against the CNT backbone alone, suggesting that the nanotubes do not possess intrinsic immunogenicity. Combination of all the described features of the vaccine system with the fact that the capacities of the anti-peptide antibodies to neutralize FMDV have been enhanced has indicated that CNT can have a valuable role in the construction of novel and effective vaccines. In vitro studies by showed selective cancer cell killing obtained by hyperthermia due to the thermal conductivity of CNT internalized into those cells. The work developed regarding the use of CNT as gene therapy vectors have shown that these engineered structures can

effectively transport the genes and drugs inside mammalian cells.

The CNT-transported genetic material has conserved the ability to express proteins³³. Detection of cancer at early stages is a critical step in improving cancer treatment. Currently, detection and diagnosis of cancer usually depend on changes in cells and tissues that are detected by a doctor's physical touch or imaging expertise. The potential for nanostructures to enter and analyze single cells suggests they could meet this need .

Artificial implants

Normally body shows rejection reaction for implants with the post administration pain but, miniature sized nanotubes and nanohorns get attached with other proteins and amino acids avoiding rejection. Also, they can be used as implants in the form of artificial joints without host rejection reaction. Moreover, due to their high tensile strength, carbon nanotubes filled with calcium and arranged/grouped in the structure of bone can act as bone substitute.

• Preservative

Carbon nanotubes and nanohorns are antioxidant in nature. Hence, they are used to preserve drugs formulations prone to oxidation. Their antioxidant property is used

in anti aging cosmetics and with zinc oxide as sunscreen dermatological to prevent oxidation of important skin components

- **Diagnostic toll**

Protein-encapsulated or protein/enzyme filled nanotubes, due to their fluorescence ability in presence of specific biomolecules have been tried as implantable biosensors. Even, Nanocapsules filled with magnetic materials, radioisotope enzymes can be used as biosensors Nanosize robots and motors with nanotubes can be used in studying cells and biological systems.

- **As catalyst**

Nanohorns offer large surface area and hence, the catalyst at molecular level can be incorporated into nanotubes in large amount and simultaneously can be released in required rate at particular time. Hence, reduction in the frequency and amount of catalyst addition can be achieved by using CNTs and CNHs .

- **As Biosensors**

CNTs act as sensing materials in pressure, flow, thermal, gas, optical, mass, position, stress, strain, chemical, and biological sensors. Some applications of carbon nanotube based sensors are given below.

Biomedical industry CNT-incorporated sensors are expected to bring about

revolutionary changes in various fields and especially in the biomedical industry sector. An example is the glucose sensing application, where regular self-tests of glucose by diabetic patients are required to measure and control their sugar levels. Another example is monitoring of the exposure to hazardous radiation like in nuclear plants/reactors or in chemical laboratories or industries. The main purpose in all these cases is to detect the exposure in different stages so that appropriate treatment may be administered. CNT-based nano sensors are highly suitable as implantable sensors. Implanted sensors can be used for monitoring pulse, temperature, blood glucose, and also for diagnosing diseases. One such example is the use of nanotubes to track glucose levels in the blood, which would allow diabetics to check their sugar levels without the need for taking samples by pricking their fingers.

6.LIMITATIONS OF CNTs

- Lack of solubility in most solvents compatible with the biological milieu (aqueous based).
- The production of structurally and chemically reproducible batches of CNTs with identical characteristics.\ Difficulty in maintaining high quality and minimal impurities.

7. MARKET OF CNT

Market size will increase from \$6 million in 2004 to \$1,070 million in 2014[40].

8. CONCLUSION

With the prospect of gene therapy, cancer treatments, and innovative new answers for life-threatening diseases on the horizon, the science of Nanomedicine has become an ever-growing field that has an incredible ability to bypass barriers. The properties and characteristics of CNTs are still being researched heavily and scientists have barely begun to tap the potential of these structures. Single and multiple walled carbon nanotubes have already proven to serve as safer and more effective alternatives to previous drug delivery. Among the various methods shown in this review the CVD method clearly emerges as the best one for large scale production of MWNTs. However, the production of SWNTs is still in the gram scale and the helical carbon nanotubes are only obtained together with linear CNTs.

REFERENCES

➤ Nikolay Dementev,^a Sebastian Osswald,^b Yury Gogotsib and Eric Orguet, Purification of carbon nanotubes by dynamic oxidation in air, *J. Mater. Chem.*, 19, 7904-7908, 2009.

➤ I. W. Chiang, B. E. Brinson, R. E. Smalley, J. L. Margrave, and R. H. Hauge. Purification and Characterization of Single-Wall Carbon Nanotubes. *J. Phys. Chem. B*, 105, 1157-1161, 2001.

➤ ai P, Nair K, Jamade S, Shah R, Ekshinge V, Jadhav N. Pharmaceutical applications of carbon tubes and nanohorns.

➤ Current Pharma eSearch Journal; 1:11-15, 2006.

➤ Pantarotto D, Partidos C, Hoebeke J, Brown F, Kramer E, Briand J. Immunization with peptide-functionalized carbon

➤ Nanotubes enhances virus-specific neutralizing antibody responses. *Chem Biol* 10: 961-966, 2003.

Kam NWS, O'Connell M, Wisdom JA, Dai HJ. Carbon nanotubes as multifunctional biological transporters

➤ And near infrared agents for selective cancer cell destruction, *Proc. Natl. Acad. Sci. U. S. A.*; 102: 11600– 11605, 2005.

➤ Kuznetsova A, Mawhinney D. Enhancement of adsorption inside of single-walled nanotubes: opening the entry ports. *Chem*

➤ Phys Lett; 321: 292-296, 2000.

➤ Deng P, Xu Z, Li J. Simultaneous determination of ascorbic acid and rutin in pharmaceutical preparations with
